

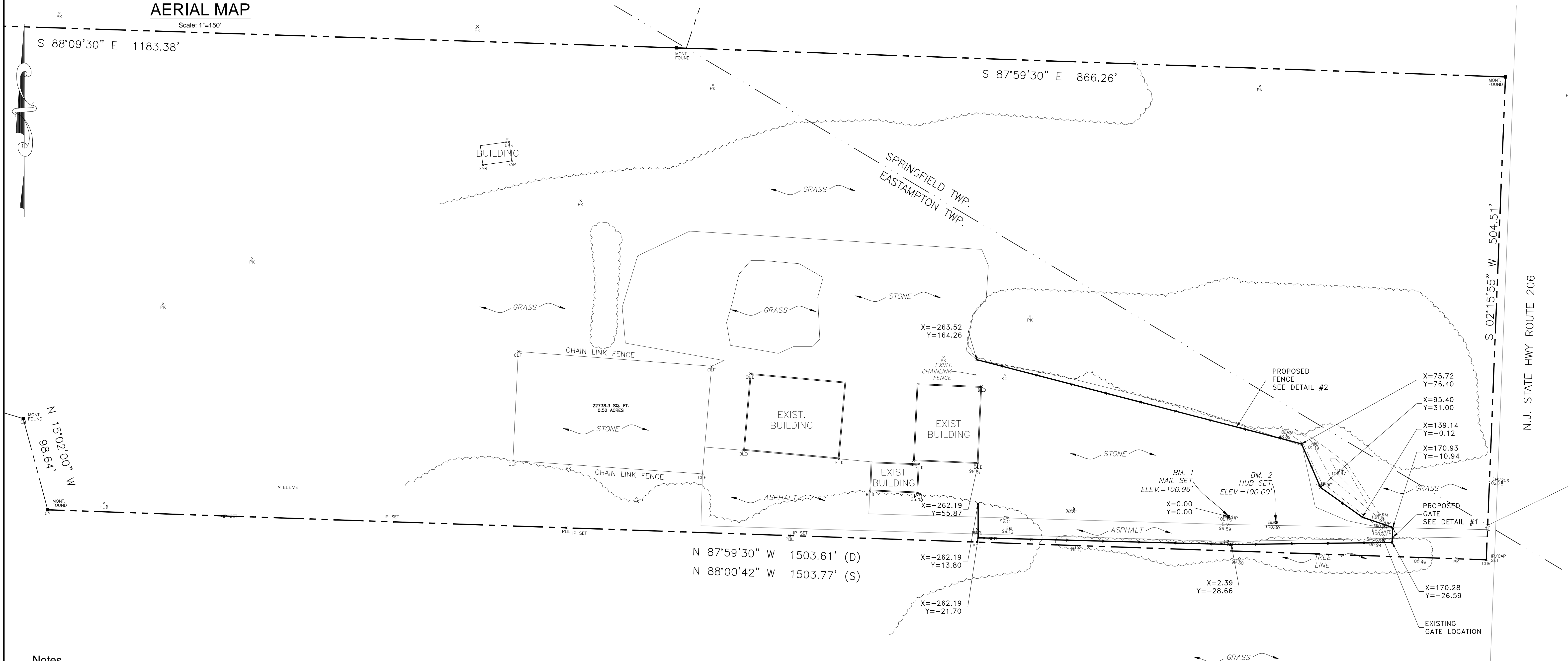

AERIAL MAP

Scale: 1"=150'



- Notes**
1. THIS PLAN IS NOT INTENDED TO DELINEATE OR DEFINE UNDERGROUND UTILITIES. THE USER IS CAUTIONED TO CONTACT NEW JERSEY ONE CALL FOR UTILITY MARKOUTS AT 1-800-272-1000.
 2. THIS DRAWING IS BASED ON ASSUMED DATUM.
 3. OUTBOUNDS ARE BASED ON SURVEY INFORMATION PROVIDED BY KLUK CONSULTANTS, LLC, DATED: 9/22/2011
 4. THE OWNER/APPLICANT IS: BRUCE FLYNN

P.O. BOX 73
JULIUSTOWN
NEW JERSEY 08043

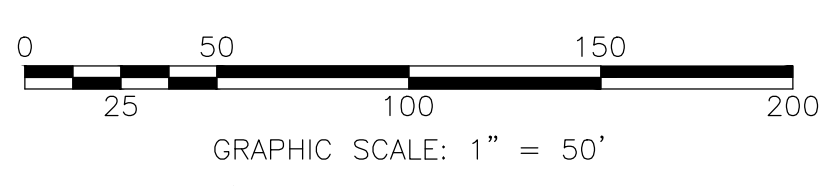

DATE	REVISION
	KRIS KLUK, PH.D., P.E.
	<i>Kluk</i>
	DATE: June 22, 2021
	NJ Professional Engineer No. 34089

PROPOSED FENCE LOCATION PLAN
 FLYNN TOWING
 LOT 10, BLOCK 800
 2619 U.S. ROUTE 206,
 EASTAMPTON, NEW JERSEY

KLUK CONSULTANTS, LLC
 2 EASTWICK DRIVE, SUITE #202
 GIBBSBORO, NEW JERSEY 08026
 TEL. (856) 566-0013

DATE: 6/18/21	SCALE: As Shown	DRAWN BY: AJD	SHEET NO.: 1 of 2
---------------	-----------------	---------------	-------------------

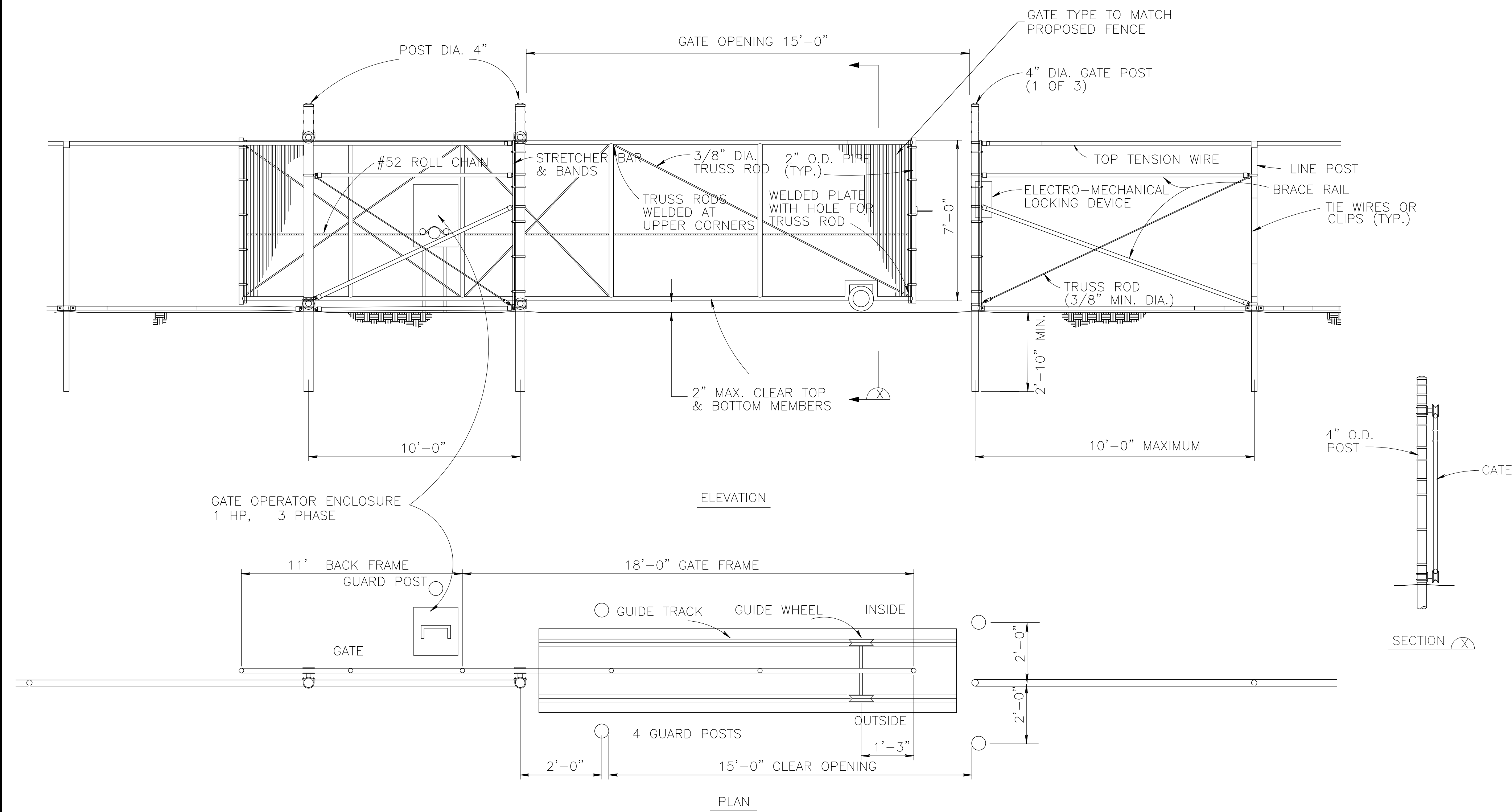

DETAIL #1
SLIDING GATE
Scale: N.T.S.

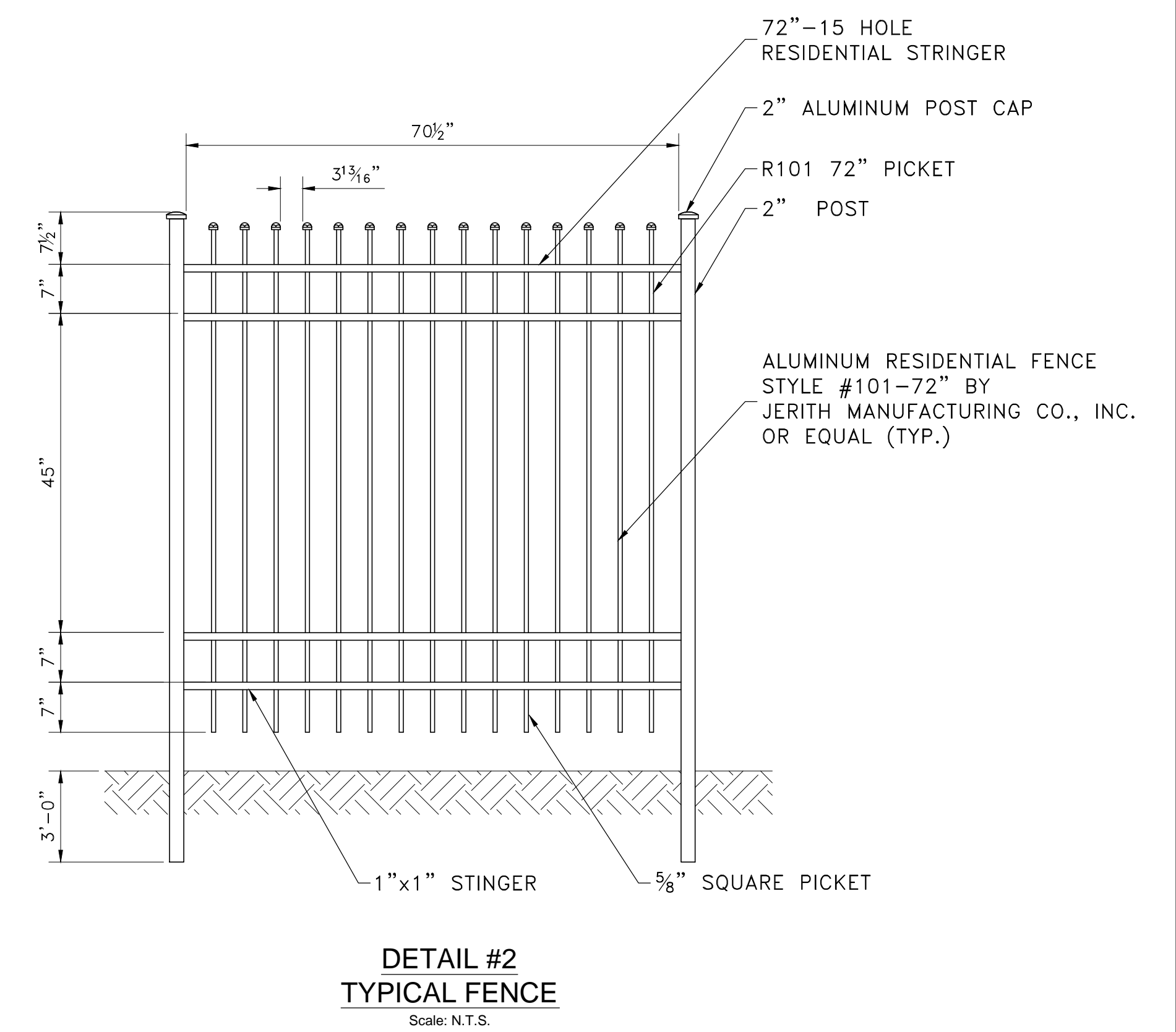
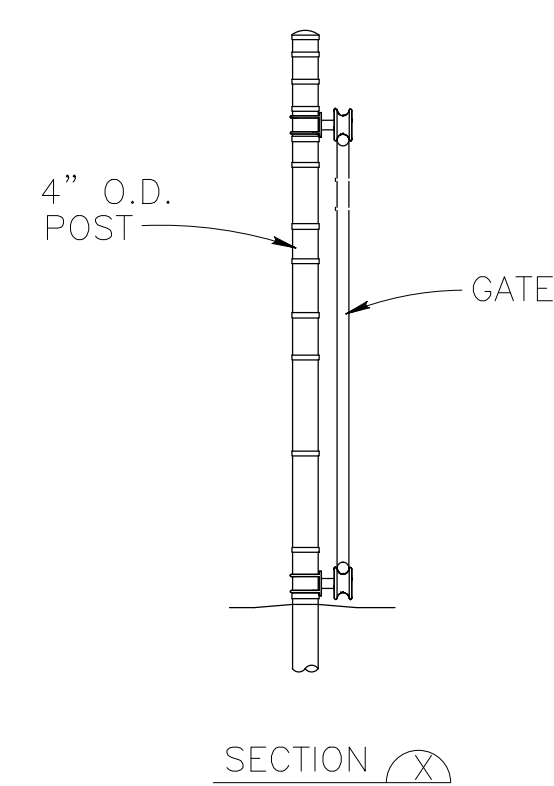

DATE	REVISION	FENCE & GATE DETAILS		KLUK CONSULTANTS, LLC	
		FLYNN TOWING		2 EASTWICK DRIVE, SUITE #202	
		LOT 10, BLOCK 800		GIBBSBORO, NEW JERSEY 08026	
		2619 U.S. ROUTE 206,		TEL. (856) 566-0013	
		EASTAMPTON, NEW JERSEY		DATE: 6/18/21	SCALE: As Shown
				DRAWN BY: AJD	SHEET NO.: 2 of 2